

# General Kitchen, Bath & Bedroom Remodeling Notes

County of Marin, Building Inspection Division

*These Notes are intended to assist in issuing simple remodel permits. It provides information on the most common requirements relating to the construction or remodeling of kitchens, bathrooms and bedrooms. It is not intended to be an exhaustive list nor to lessen or remove any other requirement of the building codes or Marin County ordinances. **The field inspector may require other code related items, which are not listed here.** Please call Division staff for further information at 415-473-6550.*

## Kitchen Notes:

1. Recessed light fixtures in the building envelope shall be IC and airtight listed.
2. All receptacles serving all countertop surfaces in kitchens and dining rooms shall have GFCI protection.
3. A minimum of two 20 amp small appliance branch circuits are required to serve counter receptacles in the kitchen, pantry, breakfast nook, dining room, and pass-throughs.
4. Where separate circuits for the garbage disposal and the dishwasher are terminated in the same box, the receptacles shall be labeled as to which appliance they serve, and the circuit breakers shall have a handle tie at the service panel. No other receptacle shall be installed in this box. The Dishwasher plug to be GFCI protected.
5. All lighting shall be high efficacy (*fluorescent or qualifying LED per Table 150.0-A*). All JA8 high efficacy lighting shall be controlled by dimmer or a manual-on vacancy sensor.
6. Countertop receptacle outlets shall be installed at each counter space 12" or wider. Receptacles shall be installed so that no point along the wall line is more than 24", measured horizontally, from a receptacle outlet in that space. One receptacle is required for peninsula counters of any length in addition to any receptacles installed in the adjoining wall space. At least one receptacle is required for island counters.
7. Countertop receptacles shall not be installed in a face up position and not more than 20" above nor more than 12" below the countertop surface.
8. Spray heads attached to hoses must be provided with an approved method of backflow prevention.
9. Dishwashers shall be connected with approved air gap devices located above the flood level of the sink. Dishwasher circuits shall be GFCI protected.
10. Hot water lines from water heaters to kitchen sinks shall be insulated for their entire length where they are exposed to in unconditioned space. (Minimum insulation thickness is 1" for 1/2" and 3/4" pipe, and 1 1/2" for 1" and larger).
10. New buildings or 'substantial remodels' must be provided with a range hood capable of 100 c.f.m. which vents to the exterior of the building.
11. When new gas piping is installed or the existing system is altered or a new gas appliance is installed, a seismic gas shut-off valve shall be installed.

## Bathroom Notes:

1. All lighting in each bathroom shall be high efficacy (*fluorescent or qualifying LED per Table 150.0-A*). All JA8 high efficacy lighting shall be controlled by dimmer or a manual-on vacancy sensor. A minimum of one fixture shall be controlled by a manual-on vacancy sensor.
2. All outlets shall be GFCI protected. An outlet is required within 3 feet of each basin location.
3. Bathroom electrical equipment requires a dedicated 20 amp circuit for each bathroom.  
**Exception:** A single 20 amp dedicated circuit may supply power to all of the bathroom GFCI receptacles within a dwelling provided the circuit is sized for the load.
4. Light fixtures in shower enclosures shall be approved for "wet location".
5. Water closets require a minimum 15" of clearance from the center line of the bowl to each side, 24" of clearance in front from the front edge of the bowl and have maximum flow of 1.28 gpm.
6. Windows with the bottom edge within 60" of a drain inlet or standing surface in a shower enclosure, or at windows adjacent to a bathtub shall be tempered.
7. All shower compartments shall have a minimum finished interior of 1024 square inches and shall also be capable of encompassing a 30" diameter circle. The curb may encroach on these size requirements. All surfaces shall be waterproof up to 72" above the drain inlet. Thresholds shall be of sufficient width to accommodate a minimum 22" clear opening. Shower doors shall not swing in. No wooden windows are allowed within a shower enclosure. Glass shower doors and partitions shall be tempered or safety glass, and shall be properly supported on all edges.
8. Control valves and showerheads shall be located on the sidewall of the shower compartment or otherwise arranged so that the showerhead does not discharge directly at the entrance to the compartment so that the bather can adjust the valves prior to stepping into the shower spray. (CPC 408.9)
9. Showers, tub-shower combinations and bathtubs shall be provided with control valves which will provide anti-scald protection. Such valves shall be of the pressure balancing and/or thermostatically controlled type. Hot water heater thermostats are not allowed to be used to control temperature for this purpose.
10. Hand-held showerheads attached to flexible hoses must be provided with an approved method of backflow prevention if the head can be placed below the flood level.

# General Kitchen, Bath & Bedroom Remodeling Notes

County of Marin, Building Inspection Division

11. Separately switched mechanical ventilation shall be provided in all bathrooms (minimum of 50 C.F.M.) vented to the exterior. Vents shall terminate not less than 3 feet in any direction from any openable window.

**Exception:** Half baths (a toilet and lavatory only) do not require mechanical ventilation if they are provided with an openable window of sufficient size.

## General Plumbing Notes:

1. Newly installed plumbing fixtures shall be water-conserving in compliance with the California Green Building & Plumbing Codes. New water closets shall not exceed 1.28 gallons per flush. New showerheads shall not exceed 2.0 gallons per minute. New lavatory faucets shall not exceed 1.2 gallons per minute. New kitchen faucets shall not exceed 1.8 gallons per minute. Existing plumbing fixtures not included in the scope of new work shall likewise be replaced (if necessary) in order to comply as follows: water closets at 1.6 gallons per flush, showerheads at 2.5 gallons per minute, and lavatory and kitchen faucets at 2.2 gallons per minute.

## Bedroom Notes:

1. All lighting shall be high efficacy (*fluorescent or qualifying LED per Table 150.0-A*) and all JA8 high efficacy lighting shall be controlled by dimmer or a manual-on vacancy sensor.
2. Bedrooms must have a minimum area of 70 square feet and a minimum ceiling height of 7' 0".
3. Bedrooms shall have openable windows to provide a minimum of 8% of its floor area in natural light and 4% of its floor area in natural ventilation.
4. Each bedroom shall have an egress window with a minimum of 5.7 square feet in openable area, with a minimum opening width of 20" and a minimum opening height of 24"; the window's lowest open edge shall not exceed 44" in height above the finished floor.

**Exception:** Grade level windows (lowest open edge at or below 44" from grade) may have an openable egress area of 5.0 square feet. An egress door (min. 3 ft. x 6 ft. 8 inches) may substitute for an egress window.

**NOTE:** Second story egress windows shall be provided with escape ladders if the building is not equipped with a fire sprinkler system.

5. Each sleeping room shall be provided with a smoke detector. In new construction, remodels, and existing areas with accessible attic, underfloor, or basement areas, the detector shall be powered by the building's 110V A/C power. (This power requirement also applies to carbon monoxide detectors.)
6. Gas appliances are not allowed to be installed in bedrooms or bathrooms unless they are of the direct-vent type or are in a sealed closet which draws combustion air from the outside air.
7. Fluorescent light fixtures and recessed fixtures in clothes closets must maintain a minimum of 6" horizontal clearance from the edge of shelves, and 12" for incandescent fixtures. Closets 70 sq. ft. or greater shall be provided with high efficacy luminaires or controlled by dimmer or a manual-on vacancy sensor. See MF-1R.
8. Bedroom receptacle outlets shall be installed at each wall space 2' or wider and no further than 12' o.c. apart. Receptacles shall be installed so that no point along the wall line is more than 6', measured horizontally, from a receptacle outlet in that space. Hallways longer than 10' require a minimum of one receptacle.

## General Notes:

1. When a permit is required, smoke detectors shall be installed inside each sleeping room at the highest point of the ceiling, centrally located in the hallway or area giving access to each separate sleeping area, and on each floor level, including basements. See the installation instructions for other locations. Carbon monoxide detectors shall be installed in buildings equipped with gas appliances and shall be installed outside sleeping areas and on each floor level, including basements. Smoke and CO detectors are required to be supplied by 110V power if the building has accessible underfloor and/or attic spaces. If possible, multiple 110V alarms shall be interconnected such that activation of one alarm shall activate all of the alarms in the dwelling unit. Battery-powered units are allowed in some circumstances.
2. When a permitted project is a new building or a structural remodel of a building which is served by natural or propane gas, or is a plumbing or mechanical permit for the installation or alteration of a gas line for the installation or relocation of a gas appliance or any new gas piping, a seismic gas shut-off valve (or excess flow valves) listed by the State of California shall be installed to protect the building at the point the gas piping enters the building prior to final.
3. In designated fire zone areas (WUI or FHSZ) all new/replacement windows shall be dual pane/tempered glass (min. one pane tempered). All new/replacement exterior doors shall be fire resistive (1 3/8" thick or rated at twenty minutes). CRC R337
4. All new/replacement exterior egress doorways shall be provided with level landings on both sides of each doorway and with thresholds which do not exceed 1 1/2" in height for out-swinging doors, 7 3/4" for in-swinging doors. Other exterior doors may have no more than two steps up to an in-swinging door with a maximum of 7 3/4" height in vertical rise. Other out-swinging exterior doors may swing over a landing which is a maximum of 7 3/4" in height from the top of

# **General Kitchen, Bath & Bedroom Remodeling Notes**

County of Marin, Building Inspection Division

the threshold to the top of a landing. Residential landings must be at least 36"x 36", or the width of the door, whichever is greater.

5. Exterior doors & landings shall be provided with an exterior light switched from the inside. Such lights shall either be fluorescent, LED or controlled by a motion sensitive, daylight sensing device. (Downward shining may be required.)
6. Dwellings shall be posted with visible address numerals with a minimum of 4" in height and a ½" wide stroke. Check with the local Fire Authority for further requirements.
7. All new residential 125 volt, 15 and 20 amp circuits **not** required to be G.F.C.I. protected must be A.F.C.I. protected. (EXCEPTION: garbage disposals and other motors.) Also, all new 125 volt, 15 and 20 amp rated receptacles must be of the tamper-resistant type.
8. LED lighting proposed to meet the high-efficacy (*fluorescent or qualifying LED per Table 150.0-A*) requirements of the Energy Code must comply with Table 150.0-A. All JA8 high efficacy lighting shall be controlled by dimmer or a manual-on vacancy sensor.
9. Electrical panels shall not be installed in bathrooms or in clothes closets, linen closets or storage rooms with easily ignitable combustibles, or in locations which are not readily accessible.
10. When mechanical equipment is newly installed in an attic space, provide a min. rough-framed 22"x 30" attic access, or an access sized for the largest component of the equipment, whichever is greater. Access through ceilings shall have a min. 30" of headroom. An access shall be located in a hallway or other readily accessible location. If not located within 12" of the service side of an appliance, a min. 24" wide walkway shall for provided to a 30"x 30" service platform. A permanent 120V receptacle and a lighting fixture shall be installed near the appliance. The switch controlling the lighting fixture shall be located at the entrance to the passage way. CRC 807.1 & CMC 304.4.1-4

H:\Handouts\KitchenBathBed Notes.doc Revised 11/14/17

# General Kitchen, Bath & Bedroom Remodeling Notes





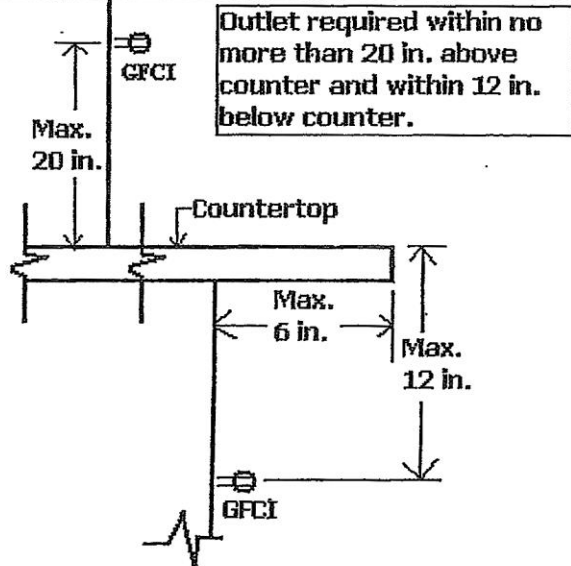
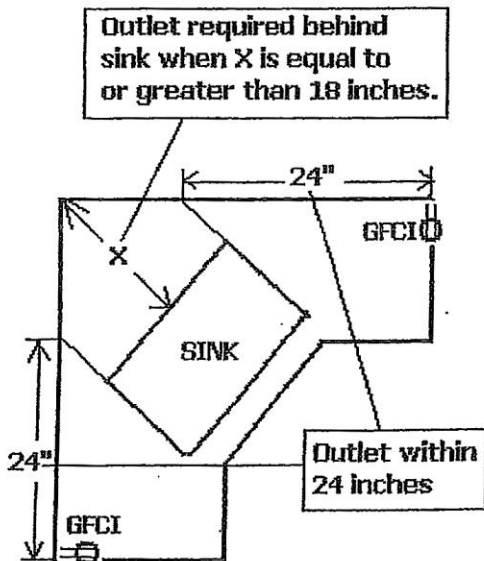
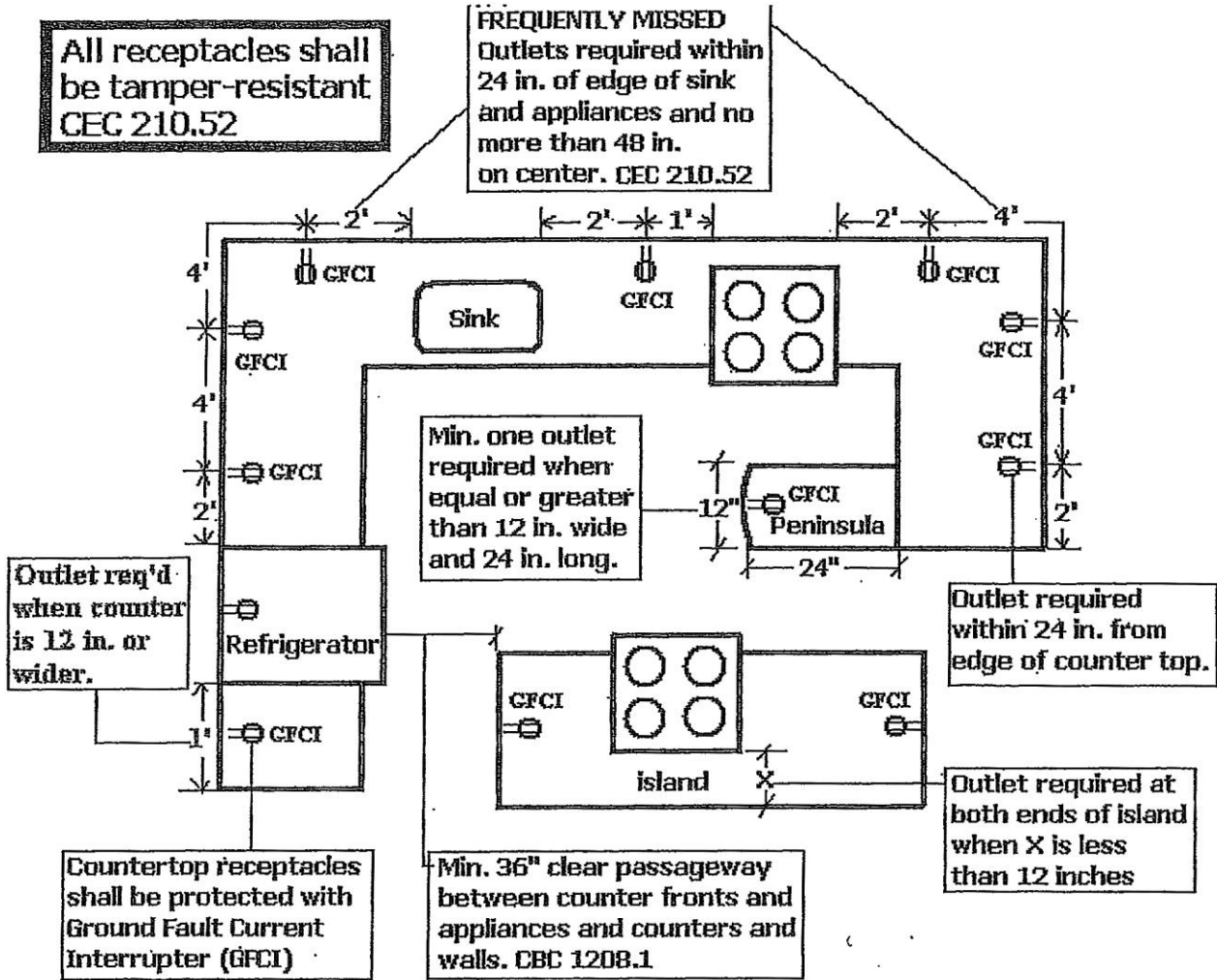





County of Marin, Building Inspection Division

## Kitchen Remodel Illustrative Handout



# General Kitchen, Bath & Bedroom Remodeling Notes

County of Marin, Building Inspection Division

ELECTRICAL PLAN	
LEGEND	
	CEILING MOUNTED LIGHT
	RECESSED LIGHT
	RCLT
	WALL MOUNTED LIGHT
	FAN
	DUPLEX RECEPTACLE OUTLET
	TELEPHONE OUTLET
	SWITCH
	DIMMER SWITCH
	DOOR BELL

